

ENGINEER AND SURVEYOR
 HOELSCHER ENGINEERING, P.C.
 11 EXECUTIVE DRIVE, SUITE 112
 FAIRVIEW HEIGHTS, ILLINOIS 62208
 (618) 924-8810

SCHOOL DISTRICTS
 K - 8: OF FALLOON TOWNSHIP SCHOOLS
 9 - 12: OF FALLOON TOWNSHIP HIGH SCHOOL DIST. #203

AREA CALCULATIONS
 GROSS AREA = 372.65 ACRES
 STREET R.O.W. = 5.847 ACRES
 NET AREA = 31.798 ACRES
 COMMON GROUND = 8.609 ACRES

FINAL PLAT OF -STONE BRIAR PHASE II-

BEING PART OF LOT 3 OF THE SOUTH HALF OF SECTION 23, TOWNSHIP 2 NORTH, RANGE 8 WEST OF THE 3RD P.M. AS RECORDED IN PLATBOOK A, PAGE 404 OF THE ST. CLAIR COUNTY RECORDERS OFFICE CITY OF OF FALLOON, ST. CLAIR COUNTY, ILLINOIS

BENCHMARKS

REFERENCE NOS 1148, 1948, TABLE IN COMMON GROUND AT STATION OF COLLINSVILLE ROAD AT CSX RAILROAD TRACKS. ELEVATION = 562.47', NAVD 88 DATUM.
 SITE: IRON PIN WITH TRAV. PT CAP, APPROX. 627' SOUTH OF CENTERLINE OF STONE BRIAR DRIVE. APPROX. COLLINSVILLE ROAD ELEVATION = 565.71'

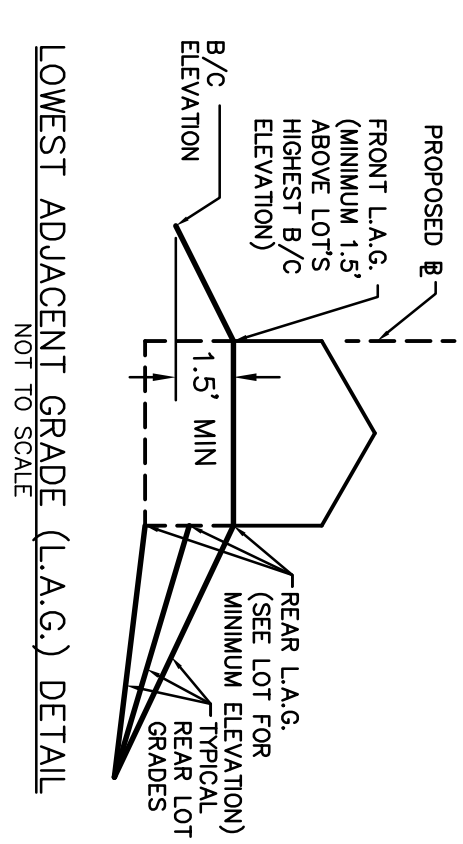

BRIAN AND SCOTT HAPPER
 BOOK 386, PAGE 607

JOHN & JEAN KILDEA
 BOOK 296, PAGE 411

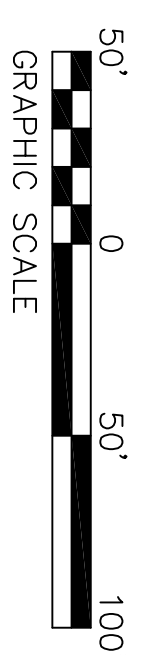
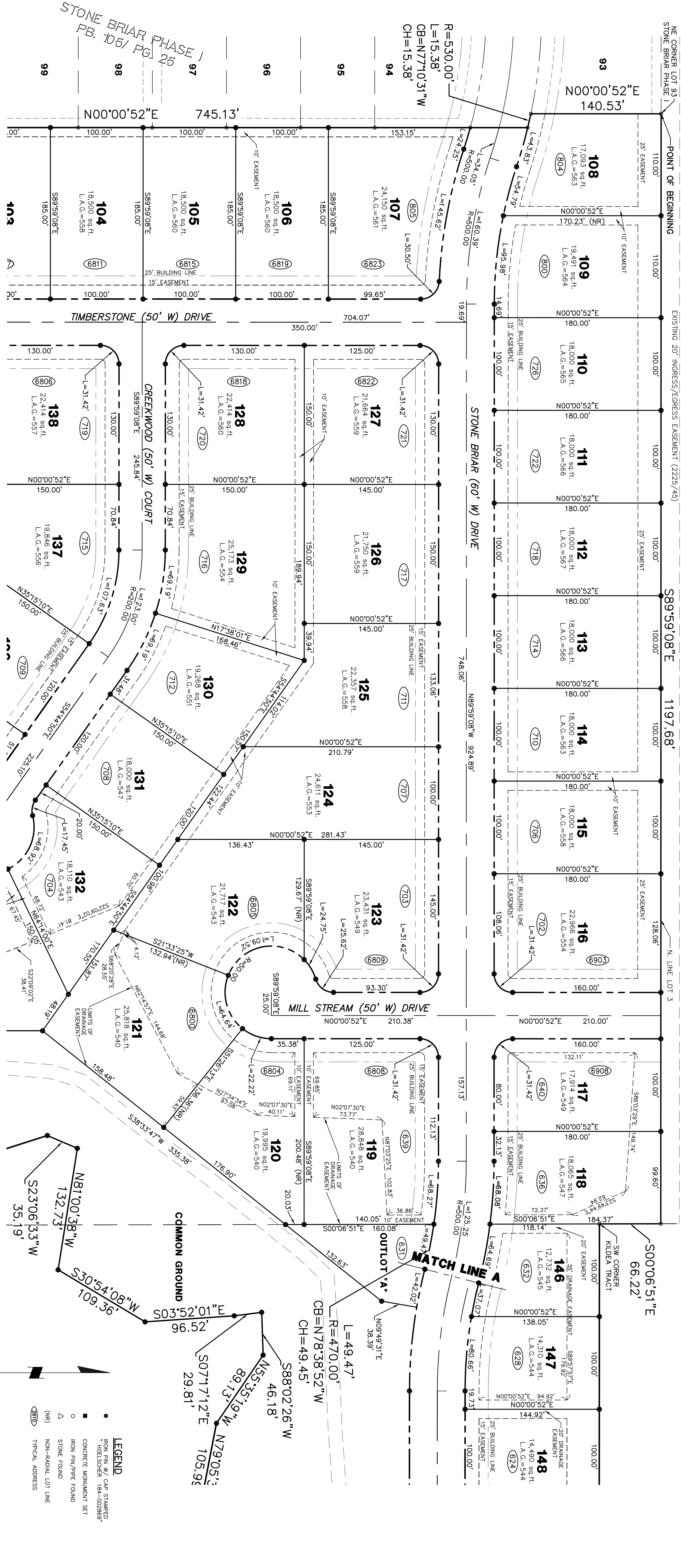

- LEGEND**
- CAP STAINERS
 - HOELSCHER 184-022869
 - CONCRETE MONUMENT SET
 - ▲ IRON PIN/PIPE FOUND
 - △ STONE FOUND
 - (NR) NON-ADJACENT LOT LINE
 - △ (NR) TYPICAL ADDRESS

WE, HOELSCHER ENGINEERING, P.C., HEREBY DECLARE THAT AT THE REQUEST OF THE OWNER, WE HAVE SURVEYED, SUBDIVIDED AND PLATTED THE TRACT OF LAND SHOWN HEREON. ALL DIMENSIONS AND OTHER ESSENTIAL INFORMATION HAVE BEEN OBTAINED FROM THE SURVEY AND SUBDIVISION. ALL REQUIRED MONUMENTS HAVE BEEN INSTALLED. ALL DIMENSIONS AND OTHER ESSENTIAL INFORMATION REQUIRED BY THE CODE OF ORDINANCE OF THE CITY OF OF FALLOON REGULATING THE PLATTING OF LAND INTO SUBDIVISIONS ADOPTED BY THE VILLAGE HAVE BEEN COMPLIED WITH. THIS PROFESSIONAL SERVICE CONFORMS TO THE CURRENT MINIMUM STANDARDS FOR A BOUNDARY SURVEY.

HOELSCHER ENGINEERING, P.C.

DALE L. WOOLARD
 I.P.L.S. #35-3321
 EXPIRATION/RENEWAL DATE:
 NOV. 30, 2008

REVISION #5: 11/29/2008 - CITY REVIEW
 REVISION #4: 9/22/2008 - CITY REVIEW

FINAL PLAT OF STONE BRIAR PHASE 2

Hoelscher Engineering, P.C.

11 Executive Drive, Suite 112
 Fairview Heights, Illinois 62208
 (618)924-8810 FAX: (618)924-8811

DRWN:	J.D.D.
CHKD:	B.D.M.
APPD:	D.L.W.
JOB NO.:	00034-01
DATE:	6/19/08
SHEET 1 OF 2	

